

GS-13 操作手冊

Operation manual

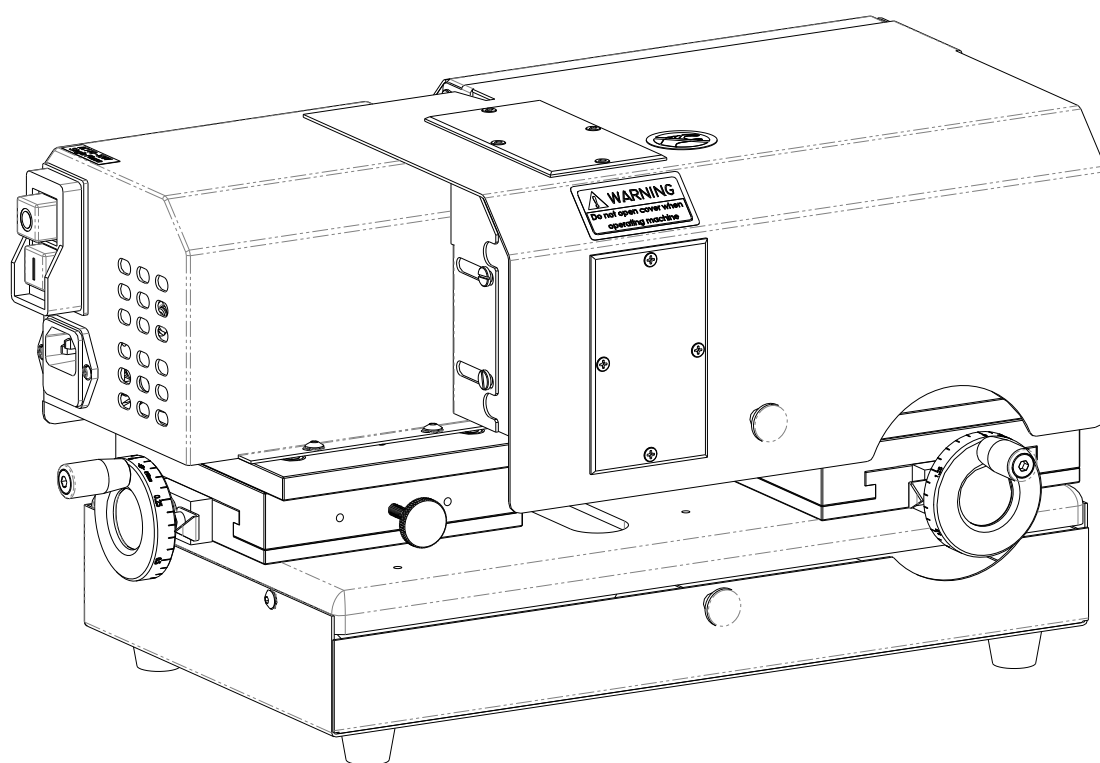

目錄 Index:

| | |
|--|------|
| I. 機器各部位名稱介紹 Machine Devices Introduction..... | P.7 |
| II. 功能 Functions | P.8 |
| X 軸移動調整 X axis adjustment | P.8 |
| Y 軸移動調整 Y axis adjustment | P.9 |
| 夾盤鎖定鈕 Spindle locker..... | P.10 |
| 搖頭開關 Toggle Switch | P.12 |
| III. 使用說明 Operation | P.14 |
| IV. 更換切斷片 Change of Cutting Wheel..... | P.17 |

I. 機器各部位名稱介紹 Machine Devices Introduction

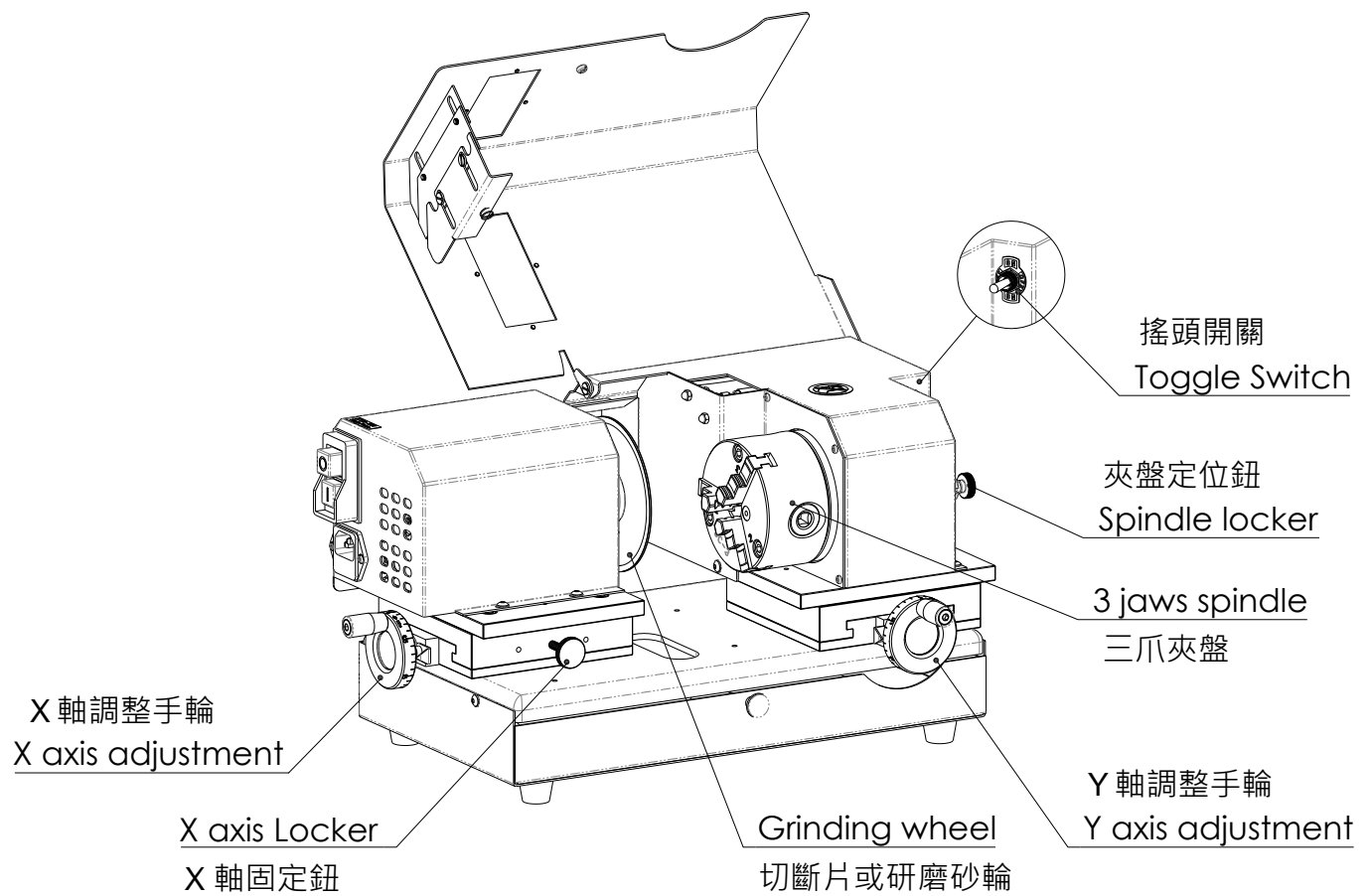

II. 功能 Functions

X 軸移動調整 X axis adjustment

用來調整切斷片或研磨砂輪的位置。

For Cutting Wheel or Grinding Wheel moving adjustment.

- ① 逆時針旋轉 X 軸固定鈕，以進行 X 軸的位置調整。

Counterclockwise the X axis Locker for X axis releases.

- ② 順時針旋轉 X 軸固定鈕，以固定 X 軸的位置。

Clockwise the X axis Locker for locking X axis.

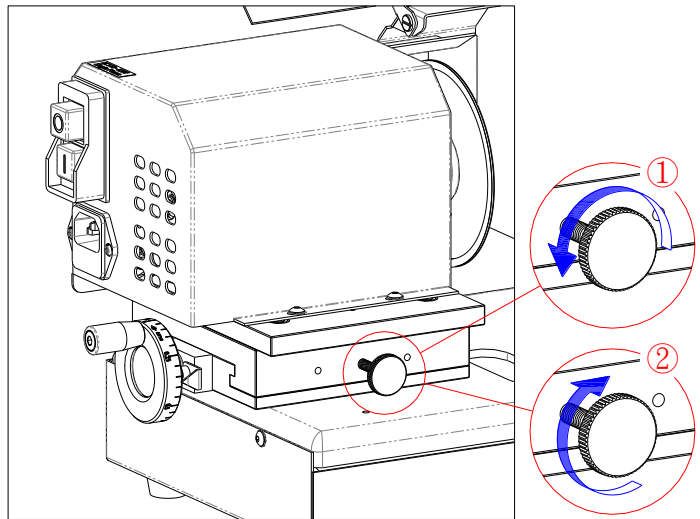

順時針旋轉手輪，X 軸向左移動。

Clockwise the X axis wheel moving X axis to the left.

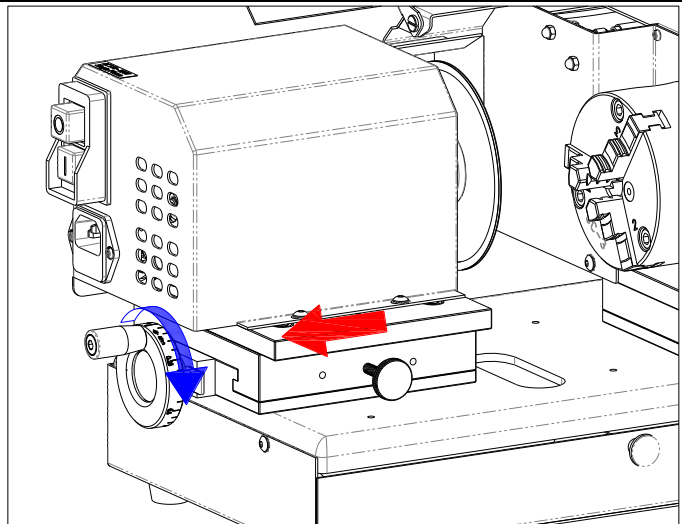

逆時針旋轉手輪，X 軸向右移動。

Counterclockwise the X axis wheel moving X axis to the right.

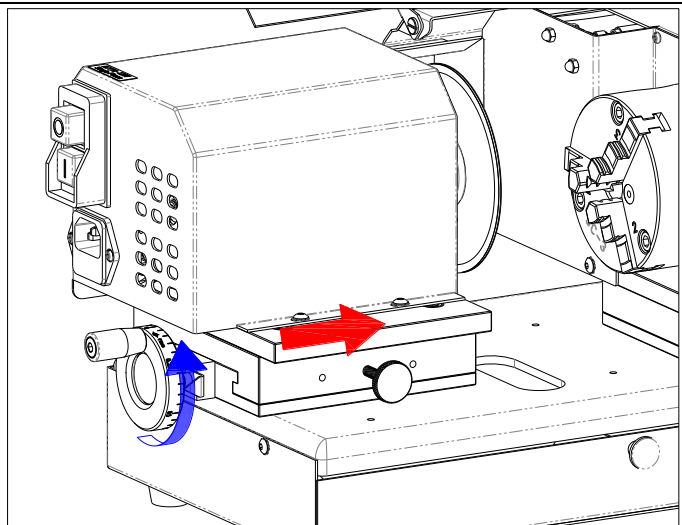

Y 軸移動調整 Y axis adjustment

用來調整工件的位置。

For workpiece moving adjustment.

順時針旋轉手輪，Y 軸向後移動。

Clockwise the Y axis wheel that will move backward the Y axis.

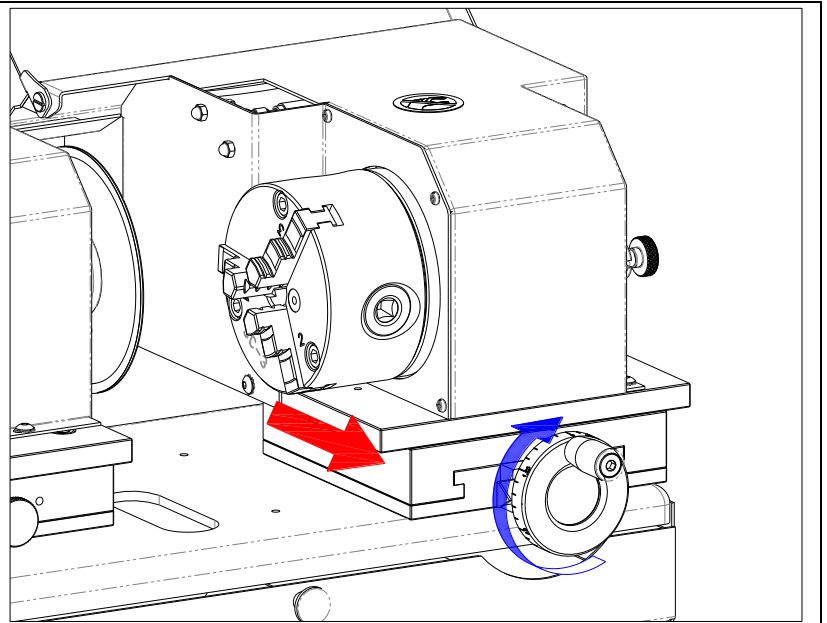

逆時針旋轉手輪，Y 軸向前移動。

Counterclockwise the Y axis wheel that will move forward the Y axis.

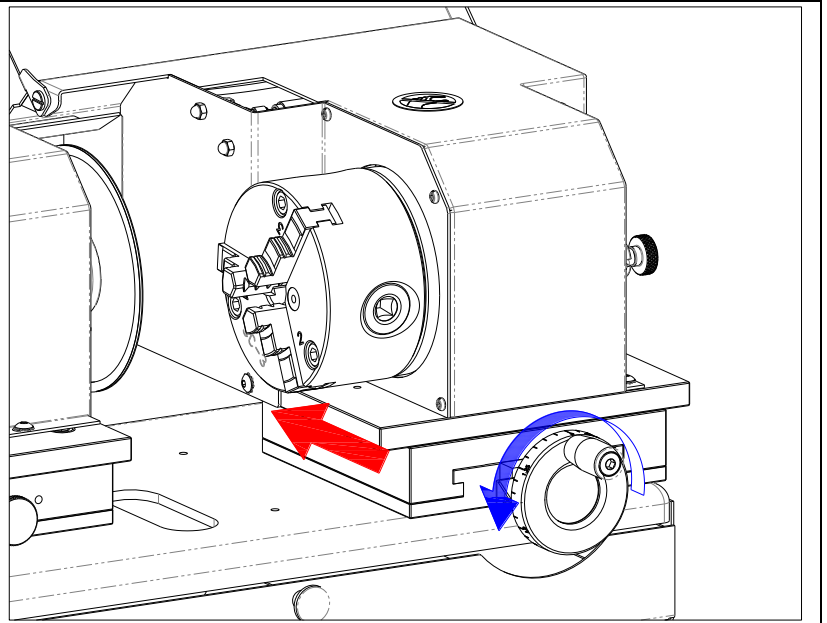

夾盤定位鈕 Spindle locker

可用來固定夾盤使其不轉動。

For locking 3 jaws spindle.

拉出夾盤定位鈕，使其定位銷轉至垂直向，並放入鎖定槽（較深的缺槽）。

Pull out the Spindle locker and turn it to the vertical, then put it into locker groove.

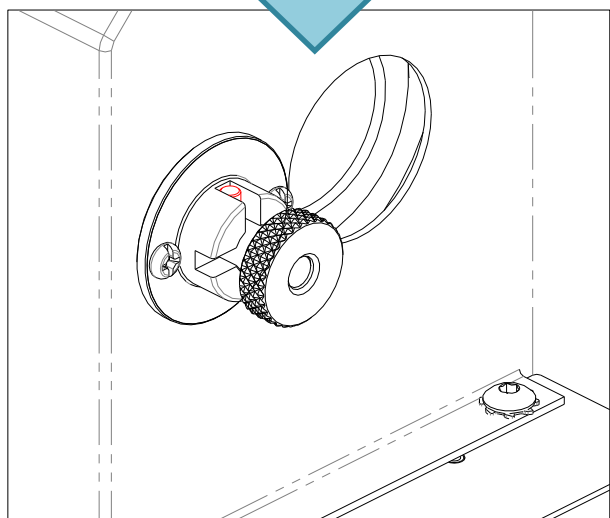
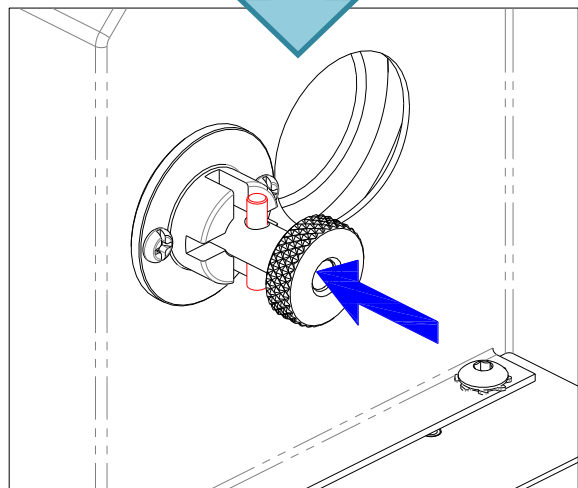
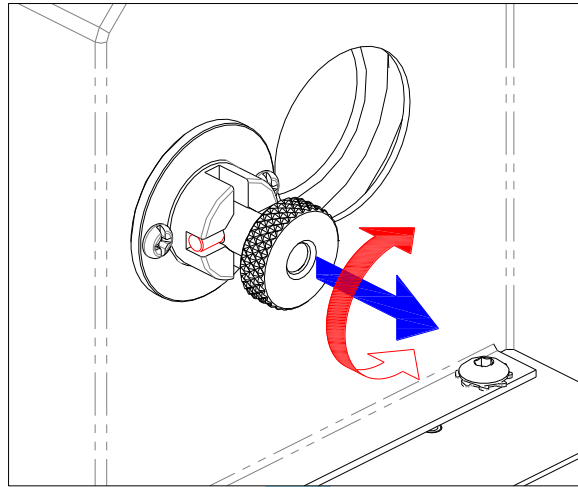

輕輕來回旋轉三爪夾盤會自動鎖定。

Turn the 3 Jaws spindle and lock on.

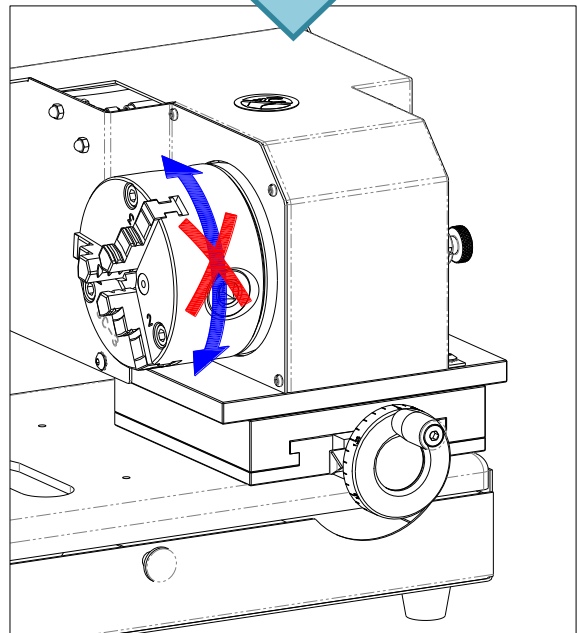
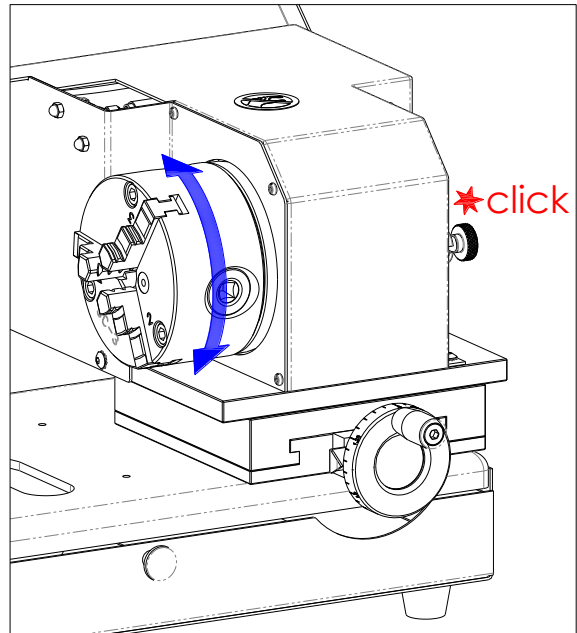

在每次操作結束之後，請習慣將夾盤定位鈕轉回水平向（較淺的缺槽），避免馬達燒毀。

Finishing your job, please keep Spindle locker to horizontal location to avoid motor burned when Toggle switch to the top and others turn on power button.

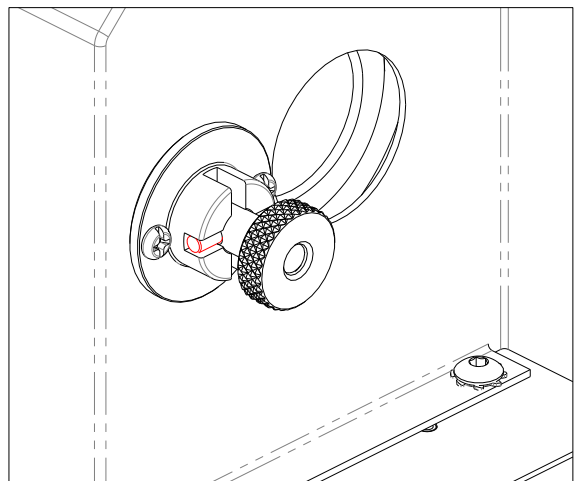

搖頭開關 Toggle Switch

此搖頭開關用來控制三爪夾盤是否旋轉。(依搖頭開關切換位置，來改變三爪夾盤是否旋轉。)

The two sides motors are optional to choose working either one or both motors at a time by using the toggle switch.

搖頭開關切至下方。

Toggle Switch to the bottom

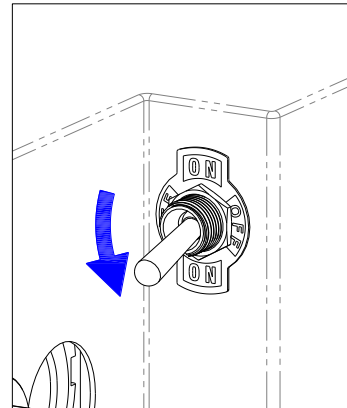

按下電源開關。

Turn the power switch on.

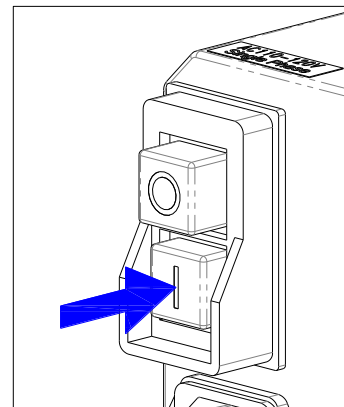

機器開始運轉，三爪夾盤不會旋轉。

Works only the left motor.

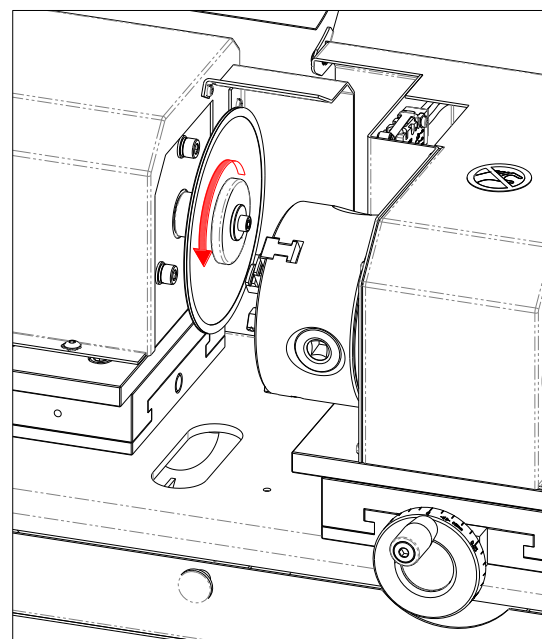

搖頭開關切至上方。

Toggle Switch to the top

※ 請確認夾盤定位鈕有轉至水平向。

※ **Please make sure the Spindle locker in the horizontal location.**

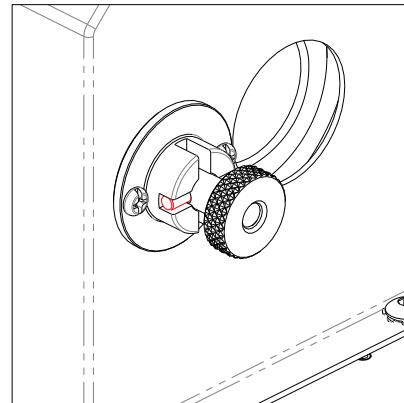
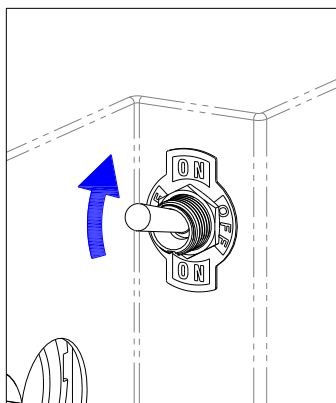

按下電源開關。

Turn the power switch on.

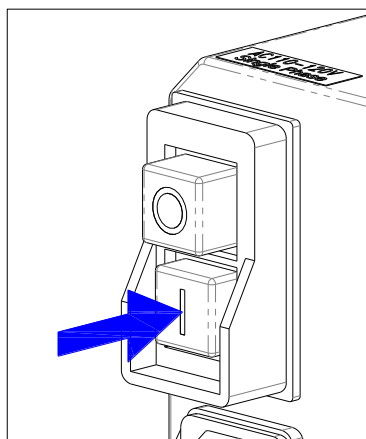

刀具和三爪夾盤皆會旋轉。

The both sides motors work.

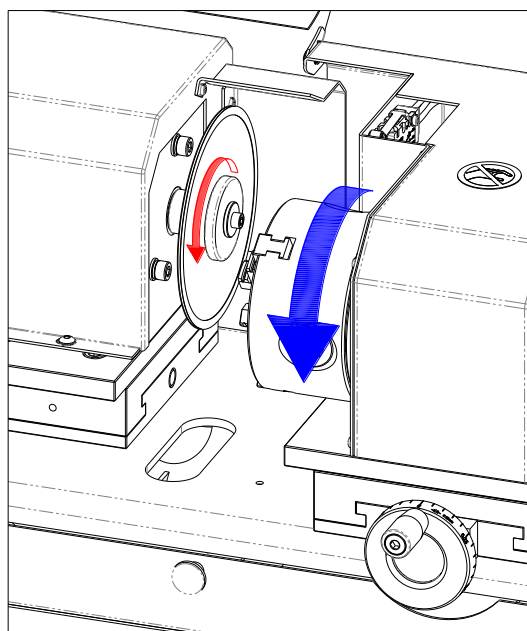

III. 使用說明 Operation

拿取要切斷的工件。 Take the workpiece.

使用所附的 T 型六角扳手鬆開夾盤。

Open the spindle with the hand tool.

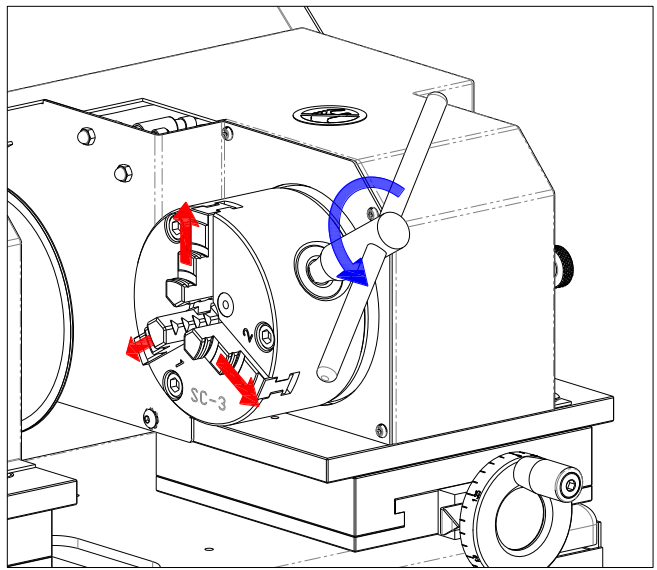

插入工件。

Insert the workpiece.

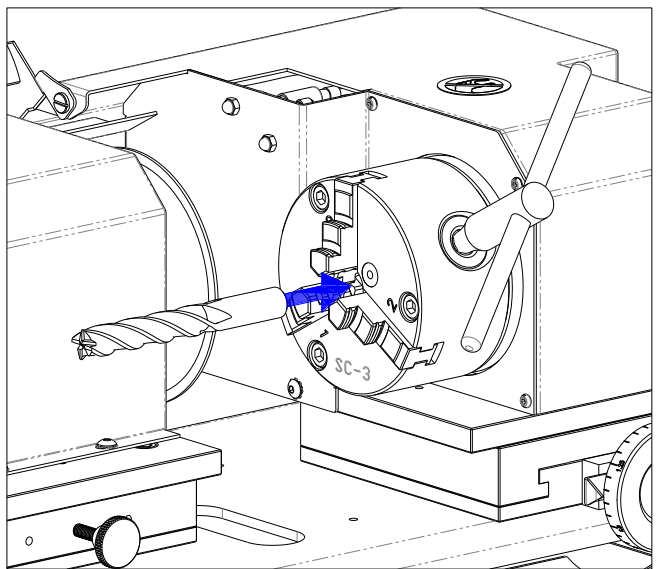

鎖緊夾盤以固定工件

Tighten the spindle

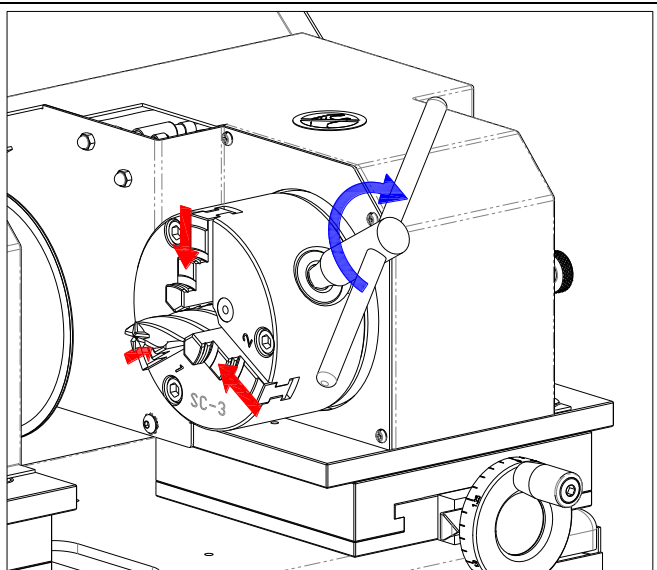

調整 X 軸及 Y 軸至理想位置。

Adjust X and Y axis to the right location.

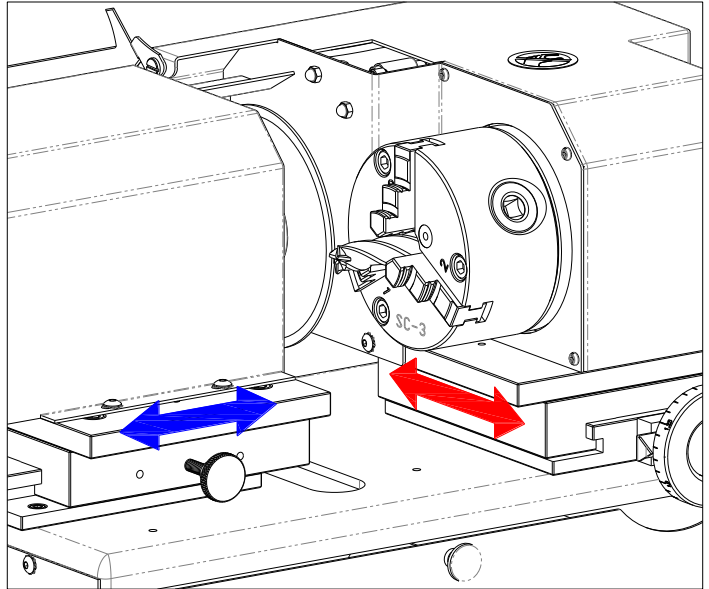

順時針旋轉 X 軸固定鈕，以固定 X 軸的位置。

Tighten the X axis Locker.

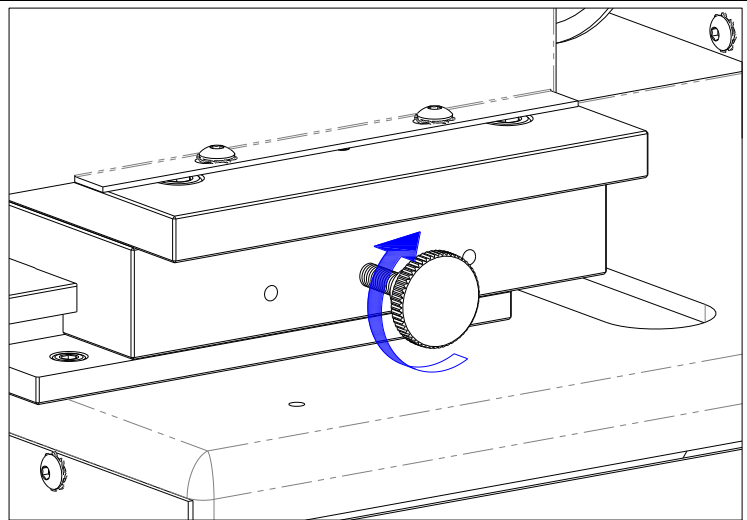

蓋上保護蓋。

Close cover.

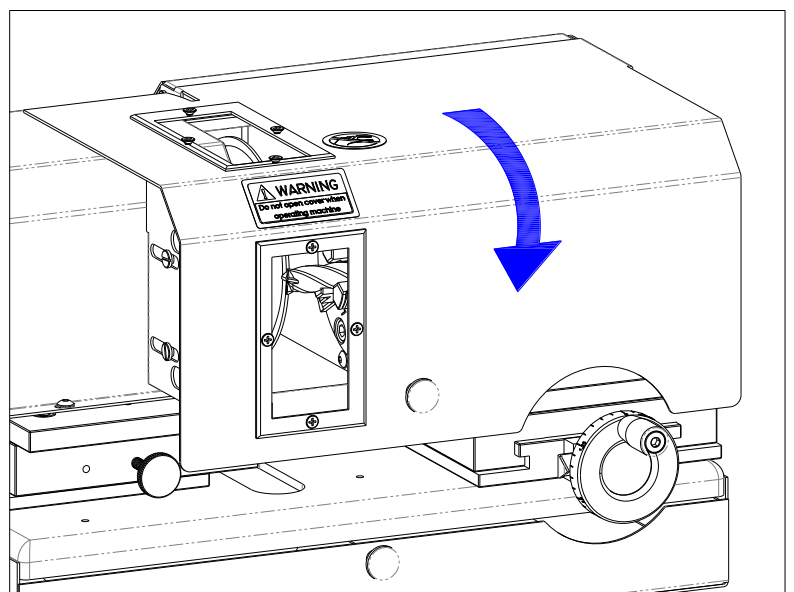

按下電源開關。

Turn the power switch on.

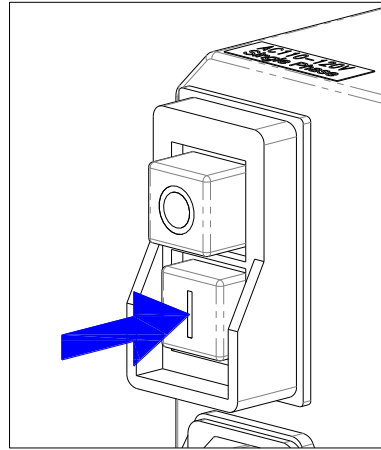

逆時針旋轉 Y 軸手輪，直至切斷完成為止。接著順時鐘旋轉手輪，直至可以取下工件即可。

Counterclockwise Y axis wheel until cutting work is completed. Then clockwise Y axis wheel until you can take workpiece out.

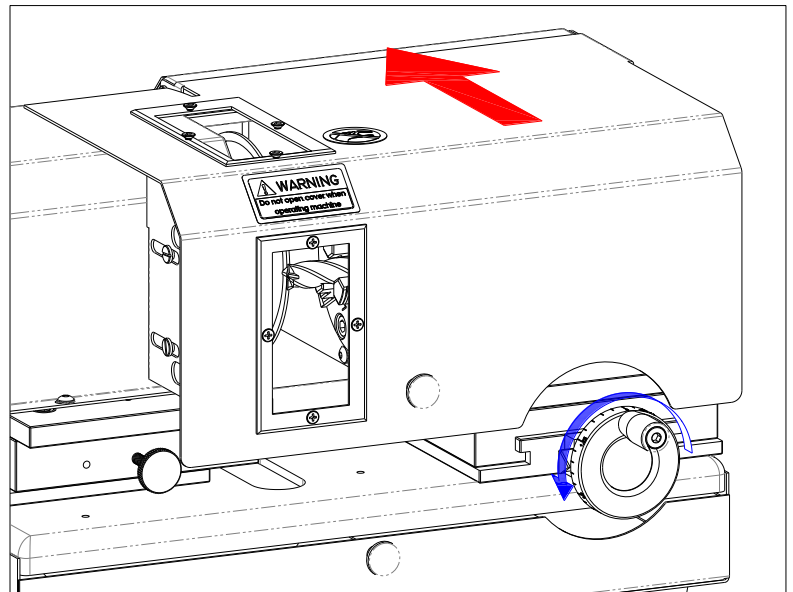

IV. 更換切斷片 Change of Cutting Wheel

